

D1133 | SWIVEL JOINT



SWIVEL JOINT FOR HEAVY DUTY WITH ENCAPSULATED BALL TRACK

The D1133 swivel joint is a variant of the basic D0002. It is the ideal swivel joint for nearly all applications in the chemical industry. It has a minimal structural length, minimal external diameter and minimal weight. The internal flange makes it possible to change the seal without removing the swivel joint from the pipeline.

In the D1133 swivel joint the ball track is encapsulated by two O-rings. Neither dirt from the outside nor product from within (in case of leakage) can reach the ball track.

Should the main seal fail, leakage is indicated through the leak detection ports.

The D1133 swivel joint can be relubricated via grease nipples if it is not provided with life time grease. If required, the balls can be removed and replaced by first removing the ball track plug.

The ball track of the steel version is hardened and polished. This gives the swivel joint a high degree of running precision and long service life, even under extreme loads. The sealing surfaces are plated with stainless steel and precision-finished to prevent corrosion. This ensures that the seal that slides along these sealing surfaces is not damaged and will seal perfectly.

The D1133 swivel joint in stainless steel is used for applications where aggressive media are encountered internally and externally, and therefore the internal parts as well as the external parts are made of stainless steel. Depending on the expected load the ball track can be hardened or unhardened. In this case a special alloy is welded into the raw material before mechanical processing.

D1133

D1133 | SWIVEL JOINT

TECHNICAL DATA D1133

Size * DN	Material	Seal material	Allowable internal pressure (gauge pressure)		Allowable temperature range **
			operational	test pressure	
50, 80, 100	product carrying parts in stainless steel	Perbunan, Viton, PTFE, special compounds	40 bar	60 bar	-50 °C to +250 °C
50, 80, 100	carbon steel		40 bar	60 bar	-50 °C to +250 °C
150, 200, 250, 300, 400	carbon steel		25 bar	37.5 bar	-50 °C to +250 °C
50, 80, 100	stainless steel / unhardened ball track		10 bar	15 bar	-50 °C to +250 °C
50, 80, 100	stainless steel / hardened ball track		40 bar	60 bar	-50 °C to +250 °C

* Larger sizes are available

** Temperature range might be restricted due to seal material

DIMENSIONS AND WEIGHTS (METRIC) D1133

Size	A	B	C	S	Bolts	Weight
DN 50	98	118.0	60.3	4	4 × M 8	3.8 kg
DN 80	98	143.5	88.9	5.6	8 × M 8	5.1 kg
DN 100	98	175.0	114.3	6.3	8 × M 10	7 kg
DN 150	160	247.0	168.3	7.1	8 × M 12	19 kg
DN 200	180	323.0	219.1	8.2	8 × M 16	33 kg
DN 250	200	380.0	273.0	9.3	12 × M 16	48 kg
DN 300	220	457.0	323.9	9.5	12 × M 20	71 kg
DN 400	228.7	552.5	406.4	9.5	12 × M 20	110 kg

Dimensions and weights for larger swivel joints are available on request

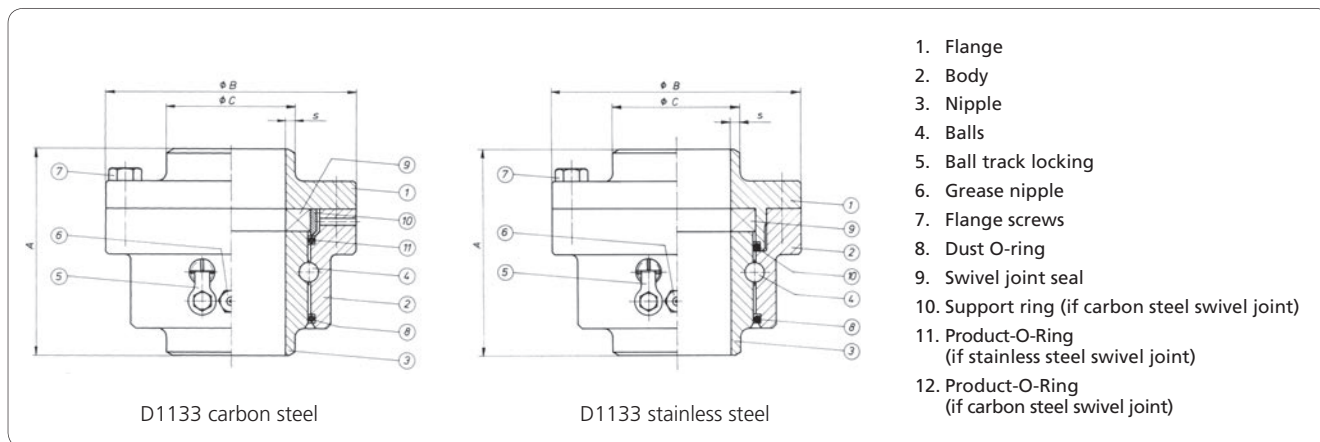

Normal attitude horizontal or vertical. If O-ring part No. 8 is facing upwards, make certain that

water cannot enter into O-ring groove (protective cover)

Whilst the content of this leaflet has been edited with the greatest care, we are not liable for any errors and/or omissions. Subject to change without notice.

D1133 EN 05/08

EMCO WHEATON

A Gardner Denver Product

Better by
Design



EMCO WHEATON GmbH
Emcostraße 2-4 · 35274 Kirchhain · Germany
Phone +49 6422 84-0 · Fax +49 6422 5100